

# HELIFLU™ TZN

**The Dedicated Turbine Flowmeter  
for Custody Transfer Measurement**

*Proven Performance*

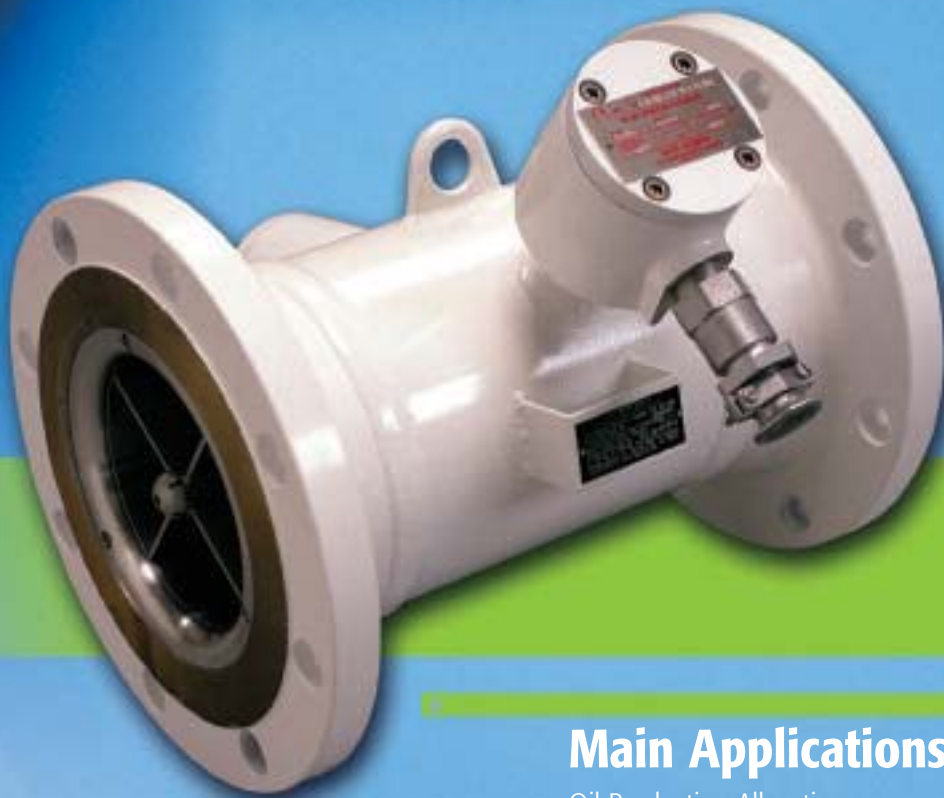

## **Main Applications**

Oil Production Allocation  
FSO, FPSO Metering  
Tanker Loading/Offloading  
Storage Management  
Pipeline Measurement



**FAURE HERMAN**  
*Mastering the Flow*

**IDEX**  
LIQUID CONTROLS GROUP



## Superior Long-term Performance and Unmatched Reliability

■ The HELIFLU™ TZN Flowmeter is designed for high accuracy measurement of liquids : from very light LPG products to heavy crude oil.

■ The advanced design and robust construction together with a wide range of available options enable the HELIFLU™ TZN Flowmeter to be used in the most severe environmental & process conditions.

■ Engineered with stainless or carbon steel bodies, the HELIFLU™ TZN Flowmeters offer an accuracy better than  $\pm 0.15\%$ , even in reduced pressure situations & an excellent repeatability ( $\pm 0.02\%$ ), making them the clear choice for custody transfer measurement.

### Typical applications :

HELIFLU™ TZN Flowmeters have an established track record in the oil industry in the following applications :

- Crude-oil measurement (on- & off-shore),
- Floating & production storage units,
- Loading & unloading at refineries,
- Ship & Tanker loading,
- Multi-product metering from crude oil to gasoline,
- Test separators,
- Off-shore liquid metering,
- Chemical plants : Ammonia, Ethylene, Propylene & acids.



FAURE HERMAN

### Key Technological Features

- Wide measurement range up to 15:1 turndown ratio
- Low pressure drop & back pressure
- Innovative design of helical profile,
- Simple, robust construction,
- Titanium rotor,
- Excellent resistance to corrosion, high pressures & temperature changes,
- Insensitivity to density changes,
- Low sensitivity to viscosity changes,
- Optional designs for low temperature and high wax / contaminants applications.

### Key Customer Advantages

- Custody transfer accuracy
- High stability & reliability,
- Low energy consumption,
- Wide range of viscosities,
- Linearity suitable for multi-product measurement,
- Low cost of ownership,
- Simplified maintenance,
- Long service life : 20,000h MTBF,
- Use for dirty crude oil applications,
- Use for dirty crude oil applications,
- Use for master metering calibration.

## A Unique Flowmeter Design

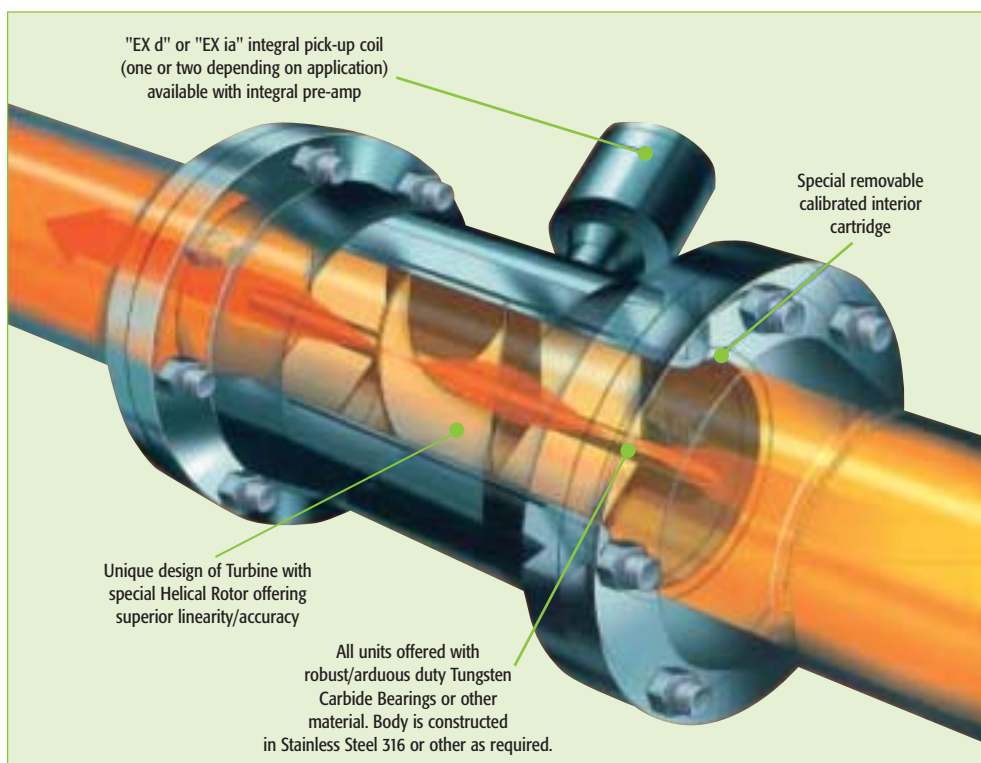

# Measurement Principle & Technical Description



Our two-blade monoblock impeller is the difference.  
 The helical free running rotor lies axially in the meter body.  
 Fluid flowing through the Heliflu™ TZN Flowmeters causes rotation at a speed directly proportional to the flow; each revolution corresponding to a precise and constant volume through the meter.  
 Magnets mounted in the rotor induce electrical pulses in an adjacent pick-up coil. These are then processed by an electrical converter & displayed as a flow rate.

A multi-blade turbine flowmeter is affected by viscosities due to the geometry of the blades.  
 With a helical rotor, the flow velocity is parallel to the blade, whatever the position may be,  
 - due to the length of the rotor, developing the flow profile correctly,  
 - the vortices at the end of the blade being reduced.

**The Heliflu™ Flowmeter has no sensitivity to density and a low sensitivity to viscosity.**

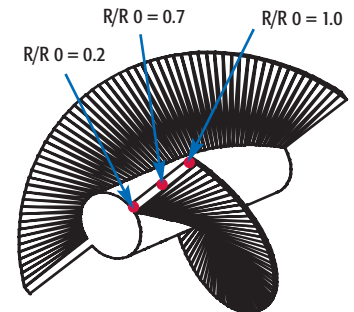

Key features of the blade as shown, result in a flat, turbulent flow profile.  
 - At each point of the blade, the relative velocity is parallel to the blade angle.  
 - The flow around the helical blade is uniform and continuous.  
 - The hydraulic load on the blade is homogeneous.

## HELIFLU™ TZN CUS for heavy liquids including DRA, wax, fibbers, chalk,...



Liquids may be mixed with DRA, and may contain wax, fibers, chalk, ....  
 Most metering solutions are affected by the presence of such components, impacting the performance and increasing operation costs of the custody transfer metering stations.

**The unique design of the patented TZN CUS eliminates those issues.**

### Cartridge design vs standard Unit

Key differences :

- a new Swept Wing Rotor
- a new Bearing Design (new thrust system and new shaft system)

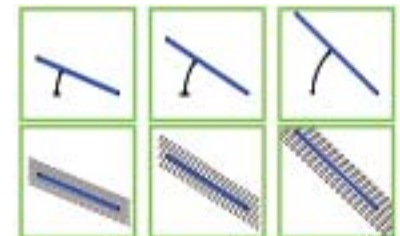

## Performances relative to viscosity

Viscosity or Product in cSt	Bearing Type/ Material & Designs	Flowrange for ± 0.25 % Linearity	Flowrange at 0.15 % Linearity
LPG or Gas Condensate	Graphite Sleeves Tungsten Carbide Shafts	10 to 100 %	10 to 100 %
VISC < 2 cSt*	Tungsten Carbide Bearings  Tungsten Carbide Shafts	10 to 100 %	10 to 100 %
VISC = 2 or < 10 cSt		10 to 100 %	10 to 100 %
VISC = 10 or < 20 cSt		10 to 100 %	10 to 100 %
Above 20 cSt Performance Data on Request VISC = 20 to 300 cSt		10/50 to 100 % according to viscosity	10/80 to 100 % according to viscosity
Above 300 cSt Performance Data on Request	Repeatability ± 0.02 % for all Units		

\* Graphite bearings for some fluids with low viscosity.

### Removable cartridge

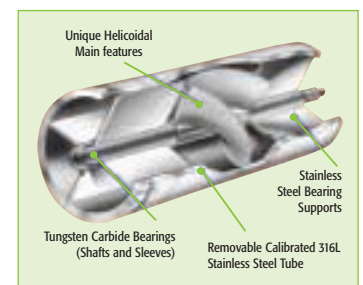

**FAURE HERMAN**



## High Accuracy Flowmeters

- The HELIFLU™ TZN Flowmeters meet International measurement Standards.
- The HELIFLU™ TZN Flowmeters meet API Recommendations for Custody Transfer Applications.
- The HELIFLU™ TZN Flowmeter rangeability is higher than 10:1.
- The HELIFLU™ TZN Flowmeters cover a wide range of viscosities from 0.1 to 350 cSt.

### 8" HELIFLU™ TZN 8-6290 - 629 to 6290 Bbl/h (100 to 1000 m³/h)

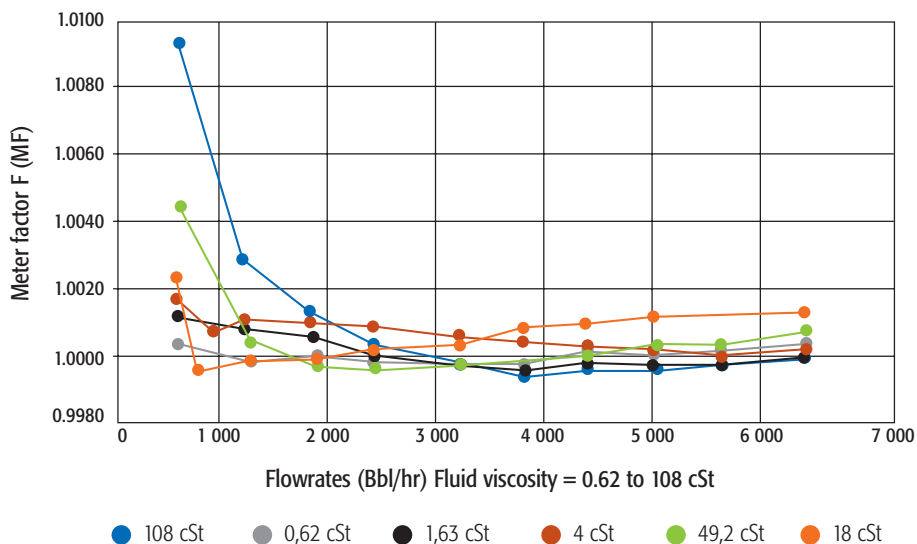

### 8" HELIFLU™ TZN Universal curve for viscosity compensation

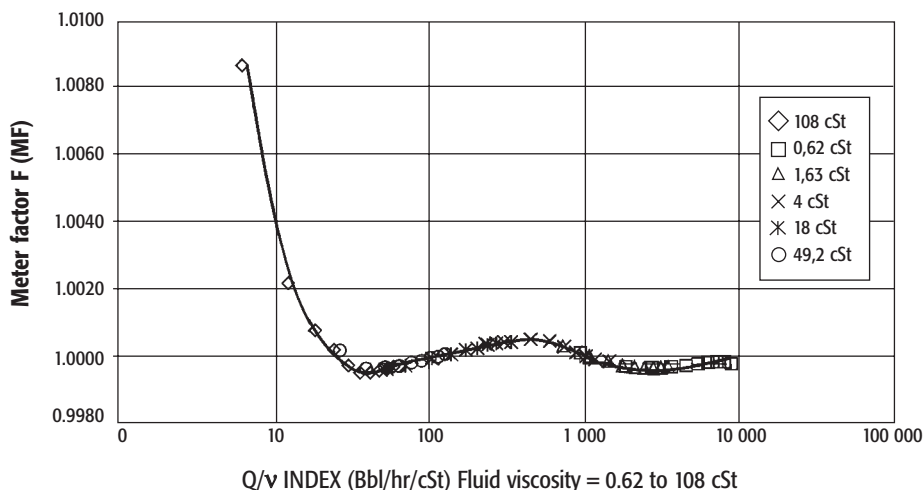

### 16" HELIFLU™ TZN Very long-term measurement stability

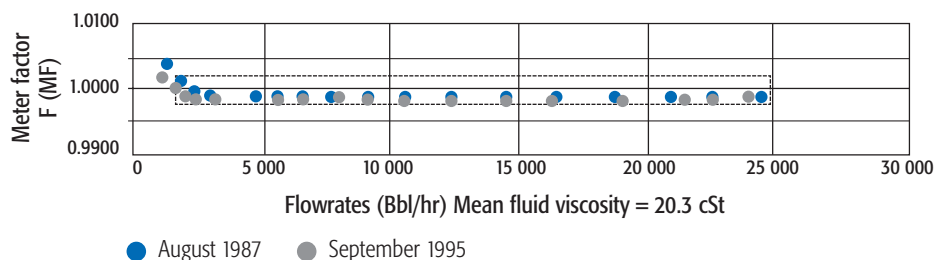

■ A commonly used method of presenting the data when a turbine meter is used in a wide range of operational viscosities is the 'Universal Curve'. This consists of a number of calibrations at various fluid viscosities which cover the range of interest. Data resulting from all the calibrations are presented as K-factor, Meter Factor or Error as a function of flowrate (or frequency) divided by kinematic viscosity. This ratio can be written  $Q/v$ .



# Pressure Drop

Pressure drop across the HELIFLU™ TZN Flowmeters is approximately 3.6 PSI at maximum flowrate with a relative density of 1 (API gravity = 10) and a kinematic viscosity of 1 cSt. The pressure drop at any flowrate Q, for kinematic viscosity  $\nu$  and relative density d can be calculated from :

$$\Delta P = 3.6 \times d \times \nu^{0.2} \times \left( \frac{Q}{Q_{\max}} \right)^2$$

with:  
 P : Pressure drop (PSI)  
 d : Relative density  
 $\nu$  : Kinematic viscosity (cSt)  
 Q : Flowrate (Bbl/h)  
 $Q_{\max}$  : Maximum flowrate (Bbl/h)

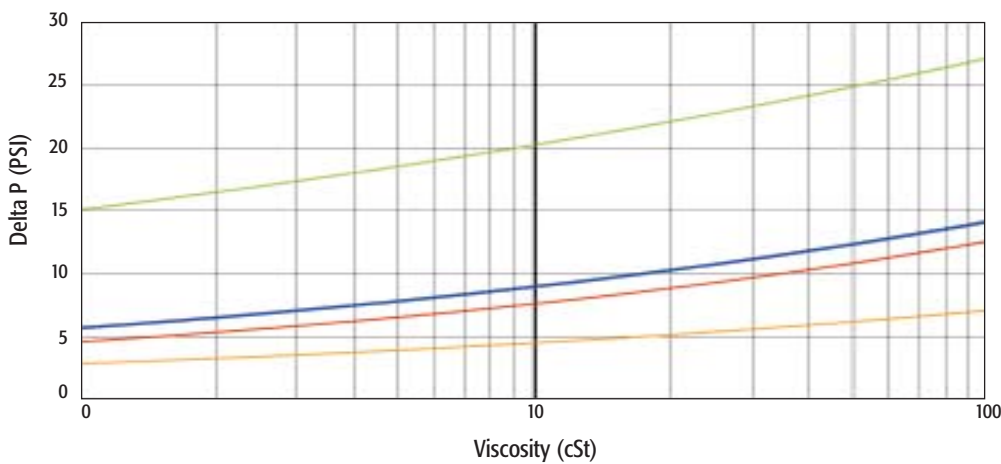

● Coriolis mass flow meter ● PD meter ● Traditional turbine meter ● HELIFLU™ meter

## HELIFLU™ TZN Flowmeter Configurations

The HELIFLU™ TZN Flowmeter can be installed either horizontally or vertically (flow upwards). The diagram below represents a typical design of a flowmeter assembly and its related equipment.

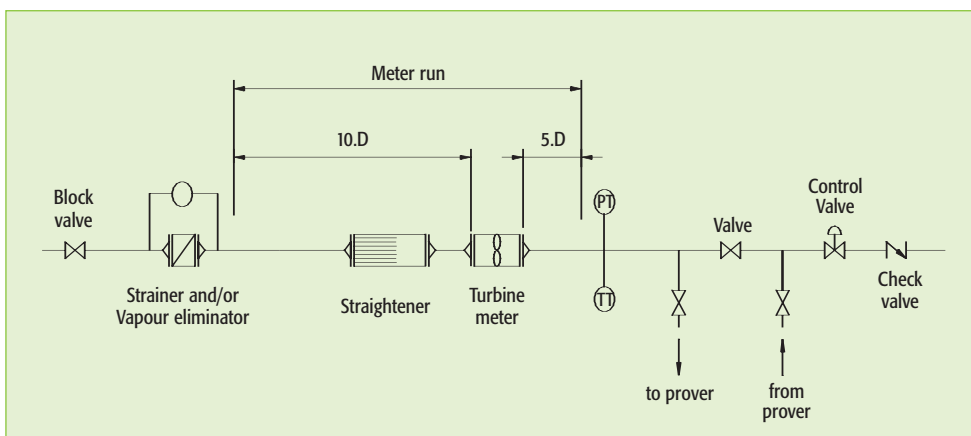

### Back Pressure

For non LPG fluids, the numerical value of the minimum absolute back pressure should be estimated from the equation:

$$P_{back} \geq 2 \times \Delta P + 1.25 \times P_i$$

with:  
 $P_{back}$  : Back pressure  
 $\Delta P$  : Meter pressure drop at max. flowrate (+ Flow conditioner)  
 $P_v$  : Vapor pressure at Max. temperature

Pressure drop through the meter is proportional to the square of the flowrate. For a constant inlet, there is a maximum flowrate at which a turbine meter can be operated within acceptable error limits before performance deteriorates. This is due to cavitation effects.

It will be noted that the lowest pressure occurs within the rotor and it is here that the cavitation may occur. This will be indicated by a sudden change in meter factor and is more likely to occur with a vapour pressure fluid with a low system operating pressure. Mounting the meter in a vertical orientation with flow from the bottom to the top will not impact the meter factor. When the flow range is too great for one meter or its prover, a bank of meters can be installed in parallel. Each meter in the bank shall operate within its minimum and maximum flow rates.



FAURE HERMAN



# USC (united standard custom) units & dimensions



Nominal Size in.	Faure Herman NEW Model No.	Faure Herman Heliflu Model No.	Flowrange Bbl/Hr*		Flowrange GPM*		Approximate K-Factor		Meter Length in.	Approx. Meter Weight (lbs.) 150# ANSI
			Min	Max	Min	Max	P/Gal	P/Bbl		
0.5	TZN 0.5-0.5	TZN 0.5-012	0.075	0.75	0.05	0.5	21000		5.125	8
0.5	TZN 0.5-1.1	TZN 0.5-025	0.157	1.57	0.11	1.1	10100		5.125	8
0.75	TZN 0.5-2.2	TZN 0.75-05	0.314	3.14	0.22	2.2	7150		5.125	9
0.75	TZN 0.75-4.4	TZN 0.75-1	0.63	6.3	0.44	4.4	1935		5.125	9
1	TZN 1.0-9	TZN 1.0-2	1.3	13	0.9	9	1935		5.125	11
1	TZN 1.0-14	TZN 1.0-3	2	20	1.4	14	757		5.125	11
1	TZN 1.0-22	TZN 1.0-5	3	30	2.2	22	337		5.125	11
1.25	TZN 1.25-35	TZN 1.25-8	5	50	3.5	35	165		5.5	13
1.25	TZN 1.25-53	TZN 1.25-12	7.5	75	5.3	53	123		5.5	13
1.25	TZN 1.25-66	TZN 1.25-15	9.4	94	6.6	66	95		5.5	13
1.25	TZN 1.25-88	TZN 1.25-20	12.6	126	8.8	88	79		5.5	13
1.5	TZN 1.5-35	TZN 1.5-8	5	50	3.5	35	165		5.5	13
1.5	TZN 1.5-53	TZN 1.5-12	7.5	75	5.3	53	123		5.5	13
1.5	TZN 1.5-66	TZN 1.5-15	9.4	94	6.6	66	95		5.5	13
1.5	TZN 1.5-88	TZN 1.5-20	12.6	126	8.8	88	79		5.5	13
2	TZN 2-130	TZN 2-30	19	190	13	130	79	3975	7	19
2	TZN 2-220	TZN 2-50	32	320	22	220	49	2386	7	19
2	TZN 2-310	TZN 2-70	44	440	31	310	34	1638	7	19
3	TZN 3-310	TZN 3-70	44	440	31	310	15	700	9.25	33
3	TZN 3-480	TZN 3-110	69	690	48	480	15	700	9.25	33
3	TZN 3-660	TZN 3-150	94	943	66	660	15	700	9.25	33
4	TZN 4-1260	TZN 4-200	126	1260	88	880	7.5	316	12	66
4	TZN 4-1890	TZN 4-300	189	1890	132	1320	6	252	12	66
6	TZN 6-2520	TZN 6-400	252	2520	177	1770		141	14	110
6	TZN 6-3770	TZN 6-600	377	3770	264	2640		103	14	110
8	TZN 8-5030	TZN 8-800	503	5030	352	3520		58	16	154
8	TZN 8-6290	TZN 8-1000	629	6290	440	4400		58	16	154
10	TZN 10-7550	TZN 10-1200	755	7550	529	5290		31	20	176
10	TZN 10-12600	TZN 10-2000	1260	12600				23	20	176
12	TZN 12-15100	TZN 12-2400	1510	15100				13	24	287
12	TZN 12-18900	TZN 12-3000	1890	18900				13	24	287
14	TZN 14-22000	TZN 14-3500	2200	22000				11	28	330
16	TZN 16-25200	TZN 16-4000	2520	25200				8	32	375
18	TZN 18-30200	TZN 18-4800	3020	30200				6	36	419
18	TZN 18-34600	TZN 18-5500	3460	34600				6	36	419
20	TZN 20-37800	TZN 20-6000	3780	37800				5	40	551

\*Extended flowrange upon request



FAURE HERMAN

Standard 5D-7D Faure Herman type

10D API type

# METRIC UNITS & DIMENSIONS



Nominal bore (n)		HELIFLU™ TZN model	* Flowrange (m³/h)		Typical (pulse/m³)	Meter length (m) (mm)	Straightener Length (s) (mm)		Recommended filtration (mm)	Weight (kg)	
in.	mm		Min at	Max			std des.	API des.		Meter	Straight
1/2	16	TZ16-012N	0.012	0.12	5200 P/liter	130	N/A	N/A	0.2	3.5	N/A
1/2	16	TZ16-025N	0.025	0.25	2600 P/liter	130	N/A	N/A	0.2	3.5	N/A
3/4	20	TZ20-05N	0.05	0.5	1600 P/liter	130	N/A	N/A	0.25	4	N/A
3/4	20	TZ20-1N	0.1	1	1600 P/liter	130	N/A	N/A	0.25	4	N/A
1	25	TZ25-2N	0.2	2	125 P/liter	130	175	N/A	0.25	5	2.5
1	25	TZ25-3N	0.3	3	125 P/liter	130	175	N/A	0.25	5	2.5
1	25	TZ25-5N	0.5	5	125 P/liter	130	175	N/A	0.25	5	2.5
1 1/4	32	TZ32-8N	0.8	8	35 P/liter	140	224	N/A	0.13	6	4
1 1/4	32	TZ32-12N	1.2	12	25 P/liter	140	224	N/A	0.3	6	4
1 1/4	32	TZ32-15N	1.5	15	18 P/liter	140	224	N/A	0.3	6	4
1 1/4	32	TZ32-20N	2	20	18 P/liter	140	224	N/A	0.3	6	4
1 1/2	40	TZ40-8N	0.8	8	35 P/liter	156	267	N/A	0.3	7	4.2
1 1/2	40	TZ40-12N	1.2	12	25 P/liter	156	267	N/A	0.3	7	4.2
1 1/2	40	TZ40-15N	1.5	15	18 P/liter	156	267	N/A	0.3	7	4.2
1 1/2	40	TZ40-20N	2	20	18 P/liter	156	267	N/A	0.3	7	4.2
2	50	TZ50-30N	3	30	20 P/liter	180	350	500	0.5	12	10
2	50	TZ50-50N	5	50	12 P/liter	180	350	500	0.5	12	10
2	50	TZ50-70N	7	70	8 P/liter	180	350	500	0.5	12	10
3	80	TZ80-70N	7	70	4 P/liter	235	560	800	1.0	20	20
3	80	TZ80-110N	11	110	4 P/liter	235	560	800	1.0	20	20
3	80	TZ80-150N	15	150	4 P/liter	235	560	800	1.0	20	20
4	100	TZ100-200N	20	200	2050	305	700	1000	1.5	25	40
4	100	TZ100-300N	30	300	1600	305	700	1000	1.5	25	40
6	150	TZ150-400N	40	400	900	356	1100	1500	1.5	45	45
6	150	TZ150-600N	60	600	650	356	1100	1500	1.5	45	45
8	200	TZ200-800N	80	800	380	406	1400	2000	2.0	75	130
8	200	TZ200-1000N	100	1000	380	406	1400	2000	2.0	75	130
10	250	TZ250-1200N	120	1200	150	508	1800	2500	2.0	115	170
10	250	TZ250-2000N	200	2000	150	508	1800	2500	2.0	115	170
12	300	TZ300-2400N	240	2400	90	610	2100	3000	3.0	190	350
12	300	TZ300-3000N	300	3000	90	610	2100	3000	3.0	190	350
14	350	TZ350-3500N	350	3500	70	711	2500	3500	3.0	210	400
16	400	TZ400-4000N	400	4000	50	813	2800	4000	3.0	295	500
18	450	TZ450-4800N	480	4800	40	914	3200	4500	5.0	385	620
18	450	TZ450-5500N	550	5500	40	914	3200	4500	5.0	385	620
20	500	TZ500-6000N	600	6000	30	1016	3600	5000	5.0	400	650

\*Extended Flowrange: upon request

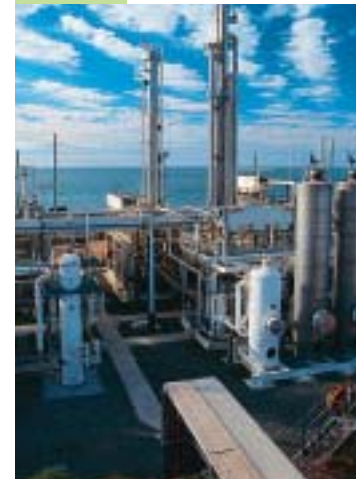

FAURE HERMAN



# Specifications



Environment	
Ambient temperature range	- 20 to + 150 °C (- 4 to + 302 °F)
- Coil	- 20 to + 80 °C (- 4 to + 176 °F)
- Preamp.	- 20 to + 180 °C (- 4 to + 356 °F)
Process temperature range	- 20 to + 180 °C (- 4 to + 356 °F)
Storage temperature	- 40 to + 60 °C (- 40 to + 140 °F)
Climatic protection	IP 66
EMC	EN 61000 & EN 5502
Safety	
Ex ia version (with coil &/or preamp)	Compatible with installation in Zones 1 & 2 Group II G
Ex d version (with coil &/or preamp)	Compatible with installation in Zones 1 & 2 Group II G
Mechanical	
Meter size	0.5 to 20"
Flange Rating	ANSI 150/300/600/900/1500/2500
Meter body material	Carbon steel, stainless steel
Flange material	Carbon steel, stainless steel
Rotor material	Titanium or Aluminium
Bearings material	Tungsten carbide
Options	Body & flanges in low temperature carbon steel, Duplex stainless steel NORSOK compliant (on request)
Performances	
Accuracy	± 0.15 %
Repeatability	± 0.02 %
Max. flow rate	0.6 to 6000 m <sup>3</sup> /h
Viscosity range	0.1 to 350 cSt (higher upon request)
Electrical options	
Pick-up coil	1 or 2
Pick-up coil + preamp.	Available
Pick-up coil + remote preamp.	Available
Local converter	Available
Pick-up-coil + preamp. + pulse multiplier	Available
Approvals	
ATEX	94/09/EC compliant
PED	97/23/EC compliant
EMC	2004/108/EC compliant
Custody transfer	MID 2004/22/EC and other national approvals (upon request)



[www.liquidcontrolsgroup.com](http://www.liquidcontrolsgroup.com)

**FAURE HERMAN** - Route de Bonnétable - BP 20154 - 72406 La Ferté-Bernard Cedex - France  
Tel. : + 33 (0)2 43 60 28 60 - Fax : + 33 (0)2 43 60 28 70

**Direct Sales** - Tel. : +33 (0)2 43 60 28 95 – Fax : +33 (0)2 43 60 28 89  
E-mail : fhprojects@idexcorp.com / www.faureherman.com

**FAURE HERMAN METER Inc.** - 6961 Brookhollow West Drive – Houston TX. 77040 (U.S.A.)  
Phone : +1713 623 0808 – Fax : +1713 623 2332 – E-mail : FHH-Sales@idexcorp.com