



Capacity to 310 GPM/70 M³/hr

Pressure to 500 PSI/34 Bar

Viscosity to 910,000 SSU (200,000 cSt)

Temperature -40° to 300° F (-40° to 150° C)



SANITARY POSITIVE DISPLACEMENT PUMPS

TRA20 Series



WRIGHT PUMP

ICEX
IDEX CORPORATION

The TRA20 Pump Series



The reliability of Wright Pump's positive displacement circumferential piston pumping principle has been proven over many decades. Its robust design and easy cleanability make it applicable for all sanitary fluids.

Wright Pumps' gentle action on shear-sensitive liquids, or slurries with soft solids, makes them the preferred technology for all areas of food processing, beverage and cosmetic manufacturing, worldwide.



CE
Pumps available
with CE mark.

Typical Applications

- ▶ **Dairy:** milk, cream, curds, butter, soft cheese, yogurt, butter, margarine, ice cream
- ▶ **Bakery:** yeast, dough, fruit filling, icing, fats and oils
- ▶ **Meats:** sausage filling, fats, broths, gelatins, pet food
- ▶ **Canned Foods:** potato salad, baby food, soups, stews, tomatoes, relishes, pudding, dressings, mayonnaise, jams and jellies
- ▶ **Beverages:** beer, mash, wort, fruit juices, fruit concentrate
- ▶ **Candy:** sugars, chocolate, cocoa butter, corn syrup, gelatin
- ▶ **Flavorings:** syrups and concentrates
- ▶ **Dressings:** Mayonnaise and other prepared sauces
- ▶ **Cosmetics:** creams, lotions, jellies, shampoos, emulsions, toothpaste
- ▶ **Pharmaceuticals:** fermentation broths, cell cultures, blood products, pill coatings and membrane separation processes
- ▶ **Industrial:** automotive paints, inks, latex, polymers



Pump Performance

Criteria	UNITS	0060	0150	0180	0300	0450	0600	1300	1800	2100	2200
Output per Revolution	Gallons	.008	.014	.029	.060	.096	.150	.250	.383	.500	.516
	Liters	.03	.052	.108	.227	.366	.568	.946	1.45	1.89	1.95
Maximum Speed	RPM	1000	800	700	600	600	600	600	600	600	600
Maximum Capacity	GPM	8	11	20	36	58	90	150	230	300	310
	M ³ /hr	1.8	2.5	4.5	8.2	13.2	20.4	34.1	52.2	68.1	70.4
Maximum Pressure	PSI	300	250	200	250	450	300	200	450	500	300
	Bar	21	17	14	17	31	21	14	31	34	21
Standard Port Size	IN	1	1.5	1.5	1.5	2	2.5	3	3	4	4
Optional Port Sizes	IN	1.5	—	2	2	—	3	—	—	—	—
Temperature Range	°F	-40° to 300° (hot clearances required for high temp. operation)									
	°C	-40° to 150° (hot clearances required for high temp. operation)									
Viscosity Range	SSU	28 to 910,000									
	cSt	1 to 200,000									

Installation Positions 4-Way Mounting

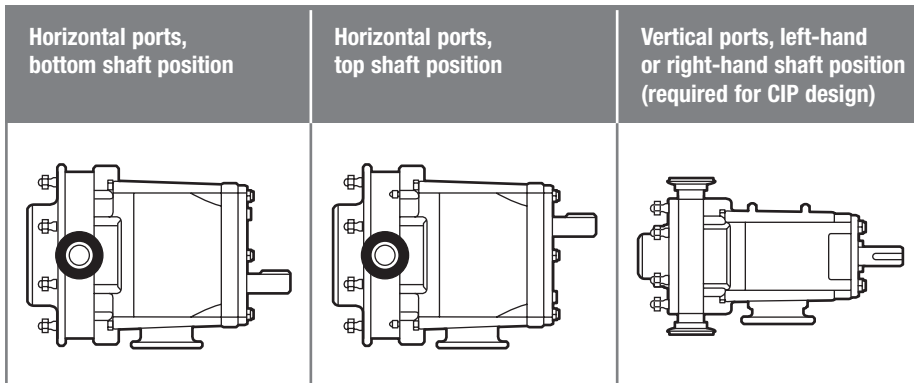

The mounting foot may be moved to any of four positions to allow horizontal or vertical porting and flexibility of driver connection.

Port Configurations

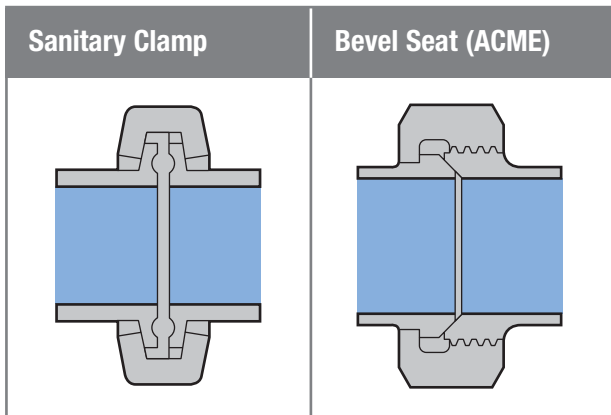

Other port configuration options include:

- ▶ DIN 11851
- ▶ RJT
- ▶ NPT
- ▶ SMS
- ▶ 150# or 300# flange

Construction

- ▶ **Casing:** 316 Stainless Steel, interior finished to 3A standards.
- ▶ **Rotors:** “Wright 808” non-galling, nickel-based alloy. Wright manufactures the material in its own foundry for maximum quality control.
- ▶ **Shafts:** One-piece, 316L Stainless Steel shafts standard on sizes 0060, 0150 & 0180. 17-4 PH High-Strength Steel on sizes 0300, 0450, 0600, 1300, 1800, 2100 & 2200.
- ▶ **Bearing Retainers:** Stainless Steel.
- ▶ **Gearcase:** Powder-coated iron gearcase standard (FDA white, RAL 9003).
- ▶ **Seals:** Single mechanical seal with Silicon Carbide / Silicon Carbide faces standard. Double mechanical seal optional.
- ▶ **Timing Gears:** Helical gear design to minimize operating noise.
- ▶ **Cleaning Options:** Strip-Clean design standard. Clean-In-Place design optional, including self-draining rotorcase (in vertical orientation) with cover O-ring exposed to cleaning fluid, and hubs and rotors ported to ensure thorough flushing action.

Performance Range

- ▶ **Capacity Range:** 0.1 to 310 gpm (0.02 to 70.4 m³/hr)
- ▶ **Pressure Range:** to 500 PSI/34 Bar
- ▶ **Temperature Range:** -40°F to +300°F (-40°C to +150°C)
Note: Hot clearances required for high temp operation
- ▶ **Viscosity Range:** 28 to 910,000 SSU (1 to 200,000 cSt)
Note: Consult factory for applications greater than 910,000 SSU/200,000 cSt. Chocolate clearances available.

Wright TRA20 Features

- ▶ Time tested and proven circumferential piston design.
- ▶ Exceptional engineering and manufacturing quality.
- ▶ Parts are interchangeable with Waukesha® Universal II series pump parts.
- ▶ Wright TRA20 pumps are drop-in replacements for equivalent sized Waukesha Universal II pumps.
- ▶ Wright can remanufacture TRA20 series or Waukesha Universal II series pumps up to four times.

Choosing between Wright TRA20 and TRA10 series pumps

- ▶ The TRA20 series allows optional Clean-In-Place design. CIP-ing can reduce cleaning time and labor between batches.
- ▶ Most TRA20 models offer higher pressure capabilities than their equivalent TRA10 model, all of which are rated to 200 PSI (14 Bar), except the model TRA10 0450, which is rated to 400 PSI (27 Bar).

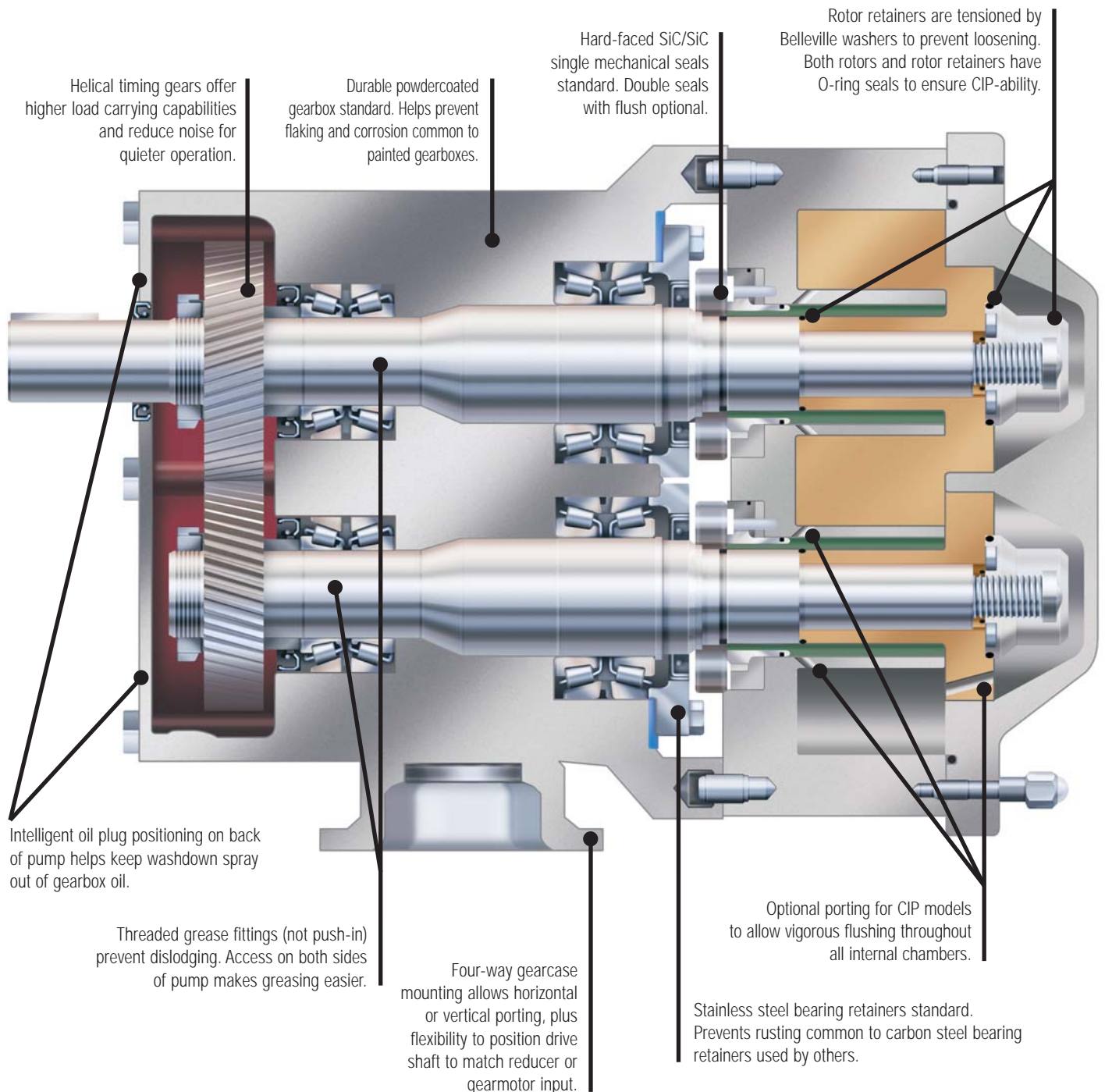

Shaft Sealing Options

...for different liquids and conditions of service

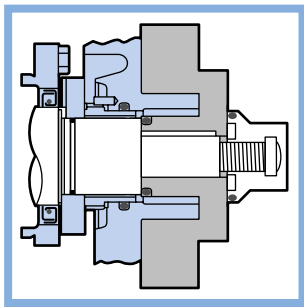

Single Mechanical Seals

- ▶ Standard Seal Faces: SiC/SiC
- ▶ Standard O-rings and Cover Seals: Buna
- ▶ Optional Faces: Carbon, Ceramic or Chrome Oxide
- ▶ Optional O-rings and Cover Seals: FKM, EPDM, Silicone

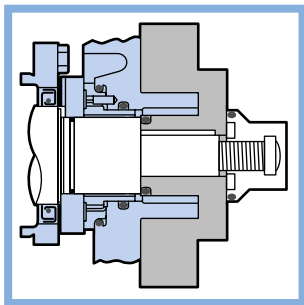

Double Mechanical Seals with Flush

- ▶ Standard Seal Faces: SiC/SiC
- ▶ Standard O-rings and Cover Seals: Buna
- ▶ Optional Faces: Carbon, Ceramic or Chrome Oxide
- ▶ Optional O-rings and Cover Seals: FKM, EPDM, Silicone

Rotors

Twin Wing Rotors Standard.

Suitable for all liquids, provides minimum pulsation.

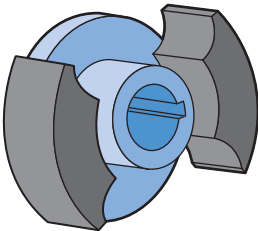

Single Wing Rotors Optional.

Provides reduced shear on shear-sensitive fluids or large solids such as fruit pieces, nut kernels, cheese curds or meats.

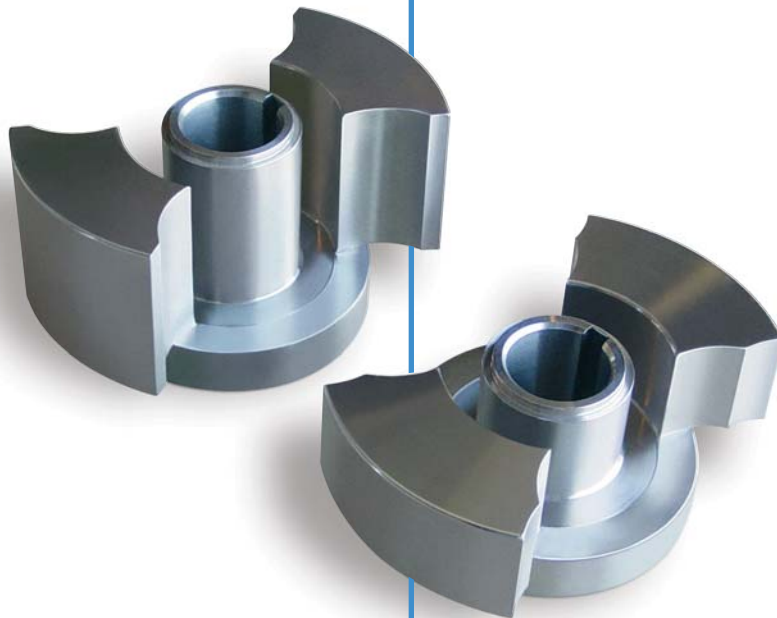
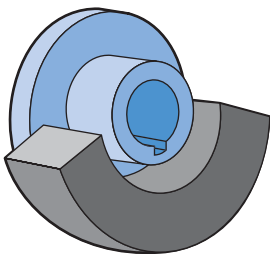

About Wright Pump

Wright Pump was established in 1996 by a group of former executives of Waukesha Cherry-Burrell. Wright first developed a line of replacement parts that were interchangeable with those of Waukesha® pumps, and later manufactured complete pumps which were drop-in replacements, but with significant improvements standard, like helical timing gears, powder-coated gearboxes and four-way mounting. Wright Pump has been a part of IDEX Corporation since 2002.

WRIGHT's Positive Displacement Circumferential Piston Pumping Principle



Wright Pumps' rotor wings (pistons) rotate around the circumference of the channel in the pump casing. This continuously generates a partial vacuum at the suction port as the rotors unmesh, causing fluid to enter the pump. The fluid is transported around the channel by the rotor wings, and is displaced as the rotor wings converge, generating pressure at the discharge port. Pump output is directly proportional to speed, and direction of flow is reversible.

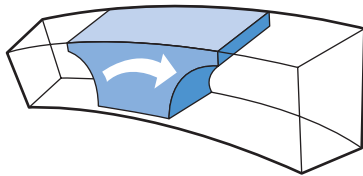

A

The deep channels in which the rotors travel provide large voids to minimize shear and bruising of solids.

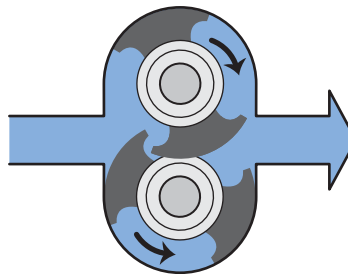

B

The rotors are made of "Wright 808" non-galling alloy, allowing extremely tight clearances between rotating and stationary surfaces, which ensures high efficiency and metering accuracy, even on thin liquids.

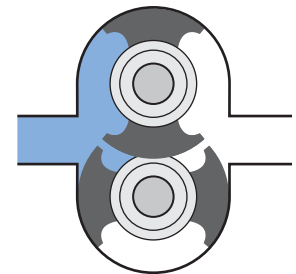

C

The forward part of each non-galling rotor rotates in a recess in the pump head to minimize deflection even at high discharge pressures.

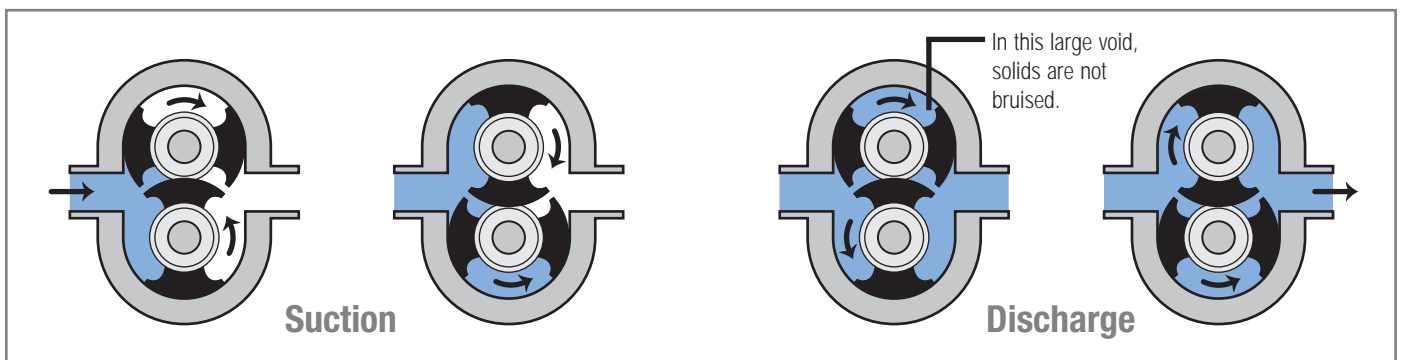

Suction

Discharge

Dimensions

Model	A	B	C	D	E	F	G	H	I	J	K	L	M	N	O	P	Q	R	S	Weight
TRA20 0060																				
in.	4.75	1.95	3.75	11.71	5.50	1.94	2.31	0.375 x 0.31 (slot)	6.82	2.93	9.61	2.12	2.00	4.21	1.5	2.79	0.875	3.49	6.97	53 lb.
mm	121	50	95	297	140	49	59	9.5 x 8 (slot)	173	74	244	54	51	107	38	71	22.23	89	177	24 kg
TRA20 0150																				
in.	4.75	1.95	3.75	11.71	5.50	1.94	2.31	0.375 x 0.31 (slot)	6.82	2.93	9.61	2.12	2.00	4.21	1.5	2.79	0.875	3.49	6.97	53 lb.
mm	121	50	95	297	140	49	59	9.5 x 8 (slot)	173	74	244	54	51	107	38	71	22.23	89	177	24 kg
TRA20 0180																				
in.	4.75	2.18	3.75	12.37	5.50	1.94	2.31	0.375 x 0.31 (slot)	6.82	2.93	9.84	2.12	2.00	4.21	1.5	3.02	0.875	3.49	6.97	53 lb.
mm	121	55	95	314	140	49	59	9.5 x 8 (slot)	173	74	250	54	51	107	38	77	22.23	89	177	24 kg
TRA20 0300																				
in.	6.25	2.78	4.25	14.49	6.86	2.31	2.56	0.438 x 0.44 (slot)	7.77	3.56	11.61	2.62	2.32	5.21	1.5	3.84	1.250	4.25	8.50	99 lb.
mm	159	71	108	368	174	59	65	11 x 11 (slot)	197	90	295	67	59	132	38	98	31.75	108	216	45 kg
TRA20 0450																				
in.	8.25	3.86	5.87	18.59	9.56	3.50	4.12	0.56 x 0.50 (slot)	10.13	5.06	15.14	3.50	2.25	7.31	2	4.73	1.625	5.37	10.75	290 lb.
mm	210	98	149	472	243	89	105	14 x 13 (slot)	257	129	385	89	57	186	51	120	41.28	136	273	132 kg
TRA20 0600																				
in.	8.25	4.14	5.87	19.14	9.56	3.50	4.12	0.56 x 0.50 (slot)	10.13	5.06	15.14	3.50	2.25	7.31	2.5	5.01	1.625	5.37	10.75	290 lb.
mm	210	105	149	486	243	89	105	14 x 13 (slot)	257	129	385	89	57	186	63	127	41.28	136	273	132 kg
TRA20 1300																				
in.	8.25	4.78	5.87	20.15	9.56	3.50	4.12	0.56 x 0.50 (slot)	10.12	5.06	15.77	3.50	2.25	7.31	3	5.65	1.625	5.37	10.75	312 lb.
mm	210	121	149	512	243	89	105	14 x 13 (slot)	257	129	401	89	57	186	76	144	41.28	136	273	142 kg
TRA20 1800																				
in.	8.50	3.45	9.00	23.26	12.38	3.75	7.25	0.56 x 0.50 (slot)	14.05	6.38	17.75	4.50	2.75	9.38	3	4.20	2.000	6.53	13.06	528 lb.
mm	216	88	229	591	314	95	184	14 x 13 (slot)	357	162	450	114	70	238	76	107	50.8	166	332	238 kg
TRA20 2100																				
in.	12.00	3.45	11.63	27.08	13.88	5.25	8.00	0.66 Ø	16.54	6.88	21.20	5.06	4.06	10.38	4	4.70	2.375	7.37	14.73	870 lb.
mm	305	88	295	688	353	133	203	16 Ø	420	175	538	129	103	264	102	119	60.33	187	374	395 kg
TRA20 2200																				
in.	8.50	3.69	9.0	24.00	12.38	3.75	7.25	0.56 x 0.19 (slot)	14.05	6.38	18.49	4.50	2.75	9.38	4	4.44	2.000	6.63	13.25	555 lb.
mm	216	94	229	610	314	95	184	14 x 5 (slot)	357	162	470	114	70	238	102	113	50.80	168	337	252 kg

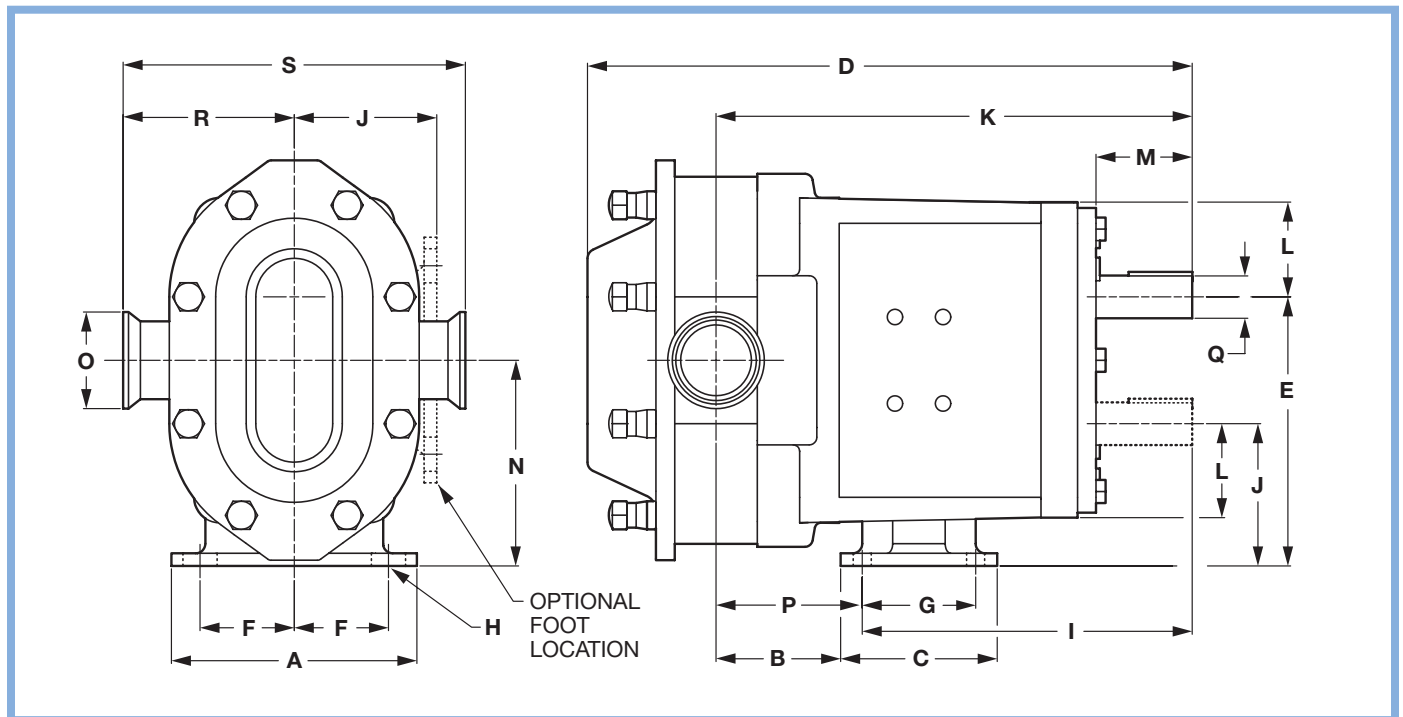

***Sanitary Pumps,
Parts, Remanufacturing & Accessories***

WRIGHT PUMP

The Right Alternative

WRIGHT PUMP

A Unit of IDEX Corporation

1409 Ellis Street • P.O. Box 164
Waukesha, WI 53187-0164

Tel: (262) 650-1925

Fax: (262) 650-1988

E-mail: info.wright@idexcorp.com

www.wrightpump.com

